

Crystal Oscillators

水晶発振器

Examples of Soldering Conditions

ハンダ付け条件の例

Vapor Phase Reflow
ベーパー フェイズ リフロー

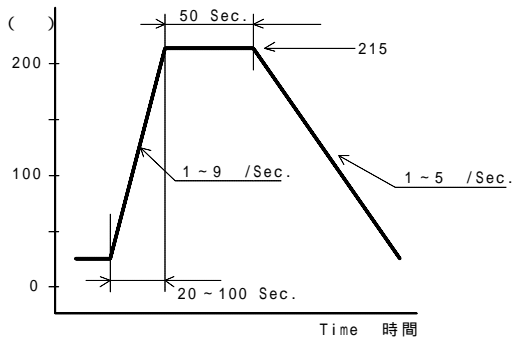

Infrared Rays Reflow
赤外線 リフロー

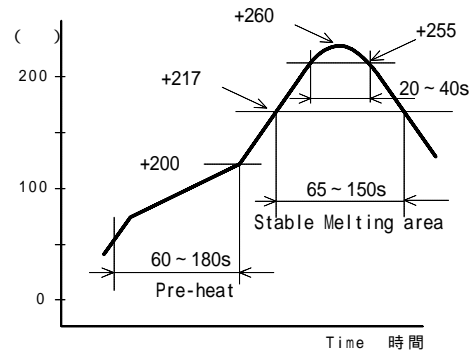

Tape and Reel Dimensions

テープ・リール寸法

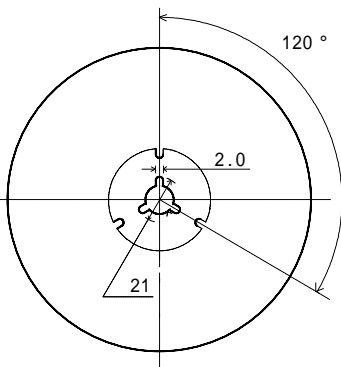
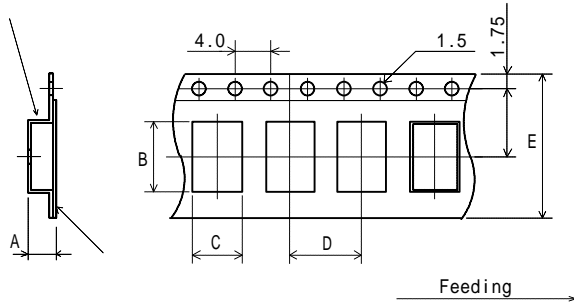

To meet EIA-481-D
EIA-481-D に適合

	A	B	C	D	E	F	G	H	Per Reel
MIN	2.45	7.9	5.4	8	16	17.5	255	80	2k
MAT	2.45	7.9	5.4	8	16	17.5	255	80	2k
CEM	2.45	7.9	5.4	8	16	17.5	255	80	2k
CAP	2.45	7.9	5.4	8	16	17.5	255	80	2k
CET	2.45	7.9	5.4	8	16	17.5	255	80	2k
MIT	2.45	7.9	5.4	8	16	17.5	255	80	2k
KD-3030	3.3	10.5	6.7	8	16	17.5	330	100	1k
TAG	1.9	6.5	4.1	8	12	13.5	255	80	2k
DUT	1.7	5.5	3.7	8	12	13.5	255	80	2k
MEG	1.75	3.6	2.9	4	8	9	180	60	2k
MOT	1.5	2.7	2.3	4	8	9	180	60	3k
SAS	6.3	14.9	10.8	16	24	25.5	330	100	1k
SAT	5.5	21.1	14.6	24	32	33.5	330	100	1k
SAT7000	7.55	20.8	14.2	20	32	33.5	330	100	1k
CAL	4.0	14.4	10	12	24	25.5	330	100	1k
COC	2.45	7.9	5.4	8	16	17.5	255	80	2k
COL	1.7	5.5	3.7	8	12	13.5	255	80	2k
COT	1.7	5.5	3.7	8	12	13.5	255	80	2k
COB	1.75	3.6	2.9	4	8	9	180	60	2k
DEL	1.7	5.5	3.7	8	12	13.5	255	80	2k
TEM	1.7	5.5	3.7	8	12	13.5	255	80	2k
MAG	1.75	3.6	2.9	4	8	9	180	60	2k

Carrier Tape キャリアテープ	PS
Top Tape トップテープ	PET
Guide Frame ガイドフレーム	PS
Center Core センターコア	PS